

# **BUNN**®

# ***TU3***

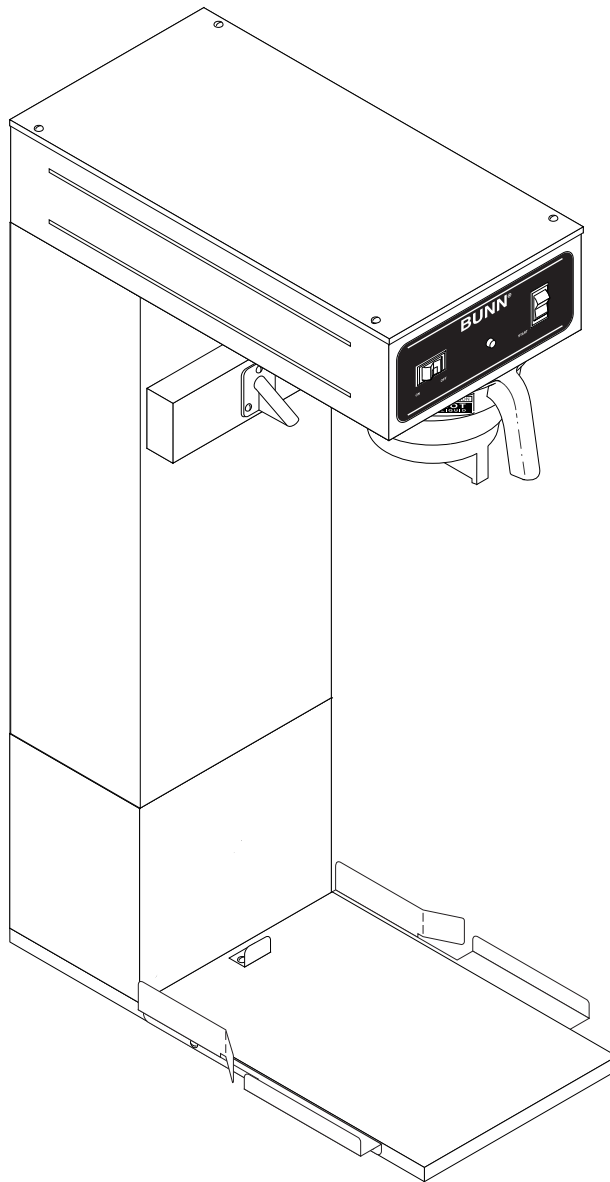

## **ILLUSTRATED PARTS CATALOG**

Designs, materials, weights, specifications, and dimensions for equipment or replacement parts are subject to change without notice.

**BUNN-O-MATIC CORPORATION**

POST OFFICE BOX 3227

SPRINGFIELD, ILLINOIS 62708-3227

PHONE: (217) 529-6601 FAX: (217) 529-6644

## **BUNN-O-MATIC COMMERCIAL PRODUCT WARRANTY**

Bunn-O-Matic Corp. ("BUNN") warrants equipment manufactured by it as follows:

- 1) All equipment other than as specified below: 2 years parts and 1 year labor.
- 2) Electronic circuit and/or control boards: parts and labor for 3 years.
- 3) Compressors on refrigeration equipment: 5 years parts and 1 year labor.
- 4) Grinding burrs on coffee grinding equipment to grind coffee to meet original factory screen sieve analysis: parts and labor for 3 years or 30,000 pounds of coffee, whichever comes first.

These warranty periods run from the date of installation BUNN warrants that the equipment manufactured by it will be commercially free of defects in material and workmanship existing at the time of manufacture and appearing within the applicable warranty period. This warranty does not apply to any equipment, component or part that was not manufactured by BUNN or that, in BUNN's judgment, has been affected by misuse, neglect, alteration, improper installation or operation, improper maintenance or repair, damage or casualty. This warranty is conditioned on the Buyer 1) giving BUNN prompt notice of any claim to be made under this warranty by telephone at (217) 529-6601 or by writing to Post Office Box 3227, Springfield, Illinois 62708-3227; 2) if requested by BUNN, shipping the defective equipment prepaid to an authorized BUNN service location; and 3) receiving prior authorization from BUNN that the defective equipment is under warranty.

**THE FOREGOING WARRANTY IS EXCLUSIVE AND IS IN LIEU OF ANY OTHER WARRANTY, WRITTEN OR ORAL, EXPRESS OR IMPLIED, INCLUDING, BUT NOT LIMITED TO, ANY IMPLIED WARRANTY OF EITHER MERCHANTABILITY OR FITNESS FOR A PARTICULAR PURPOSE.** The agents, dealers or employees of BUNN are not authorized to make modifications to this warranty or to make additional warranties that are binding on BUNN. Accordingly, statements by such individuals, whether oral or written, do not constitute warranties and should not be relied upon.

If BUNN determines in its sole discretion that the equipment does not conform to the warranty, BUNN, at its exclusive option while the equipment is under warranty, shall either 1) provide at no charge replacement parts and/or labor (during the applicable parts and labor warranty periods specified above) to repair the defective components, provided that this repair is done by a BUNN Authorized Service Representative; or 2) shall replace the equipment or refund the purchase price for the equipment.

**THE BUYER'S REMEDY AGAINST BUNN FOR THE BREACH OF ANY OBLIGATION ARISING OUT OF THE SALE OF THIS EQUIPMENT, WHETHER DERIVED FROM WARRANTY OR OTHERWISE, SHALL BE LIMITED, AT BUNN'S SOLE OPTION AS SPECIFIED HEREIN, TO REPAIR, REPLACEMENT OR REFUND.**

In no event shall BUNN be liable for any other damage or loss, including, but not limited to, lost profits, lost sales, loss of use of equipment, claims of Buyer's customers, cost of capital, cost of down time, cost of substitute equipment, facilities or services, or any other special, incidental or consequential damages.

## TABLE OF CONTENTS

Electrical and Operating Controls .....	18
Funnel Assembly .....	22
Numerical Index .....	24
Strainer/Flow Control, Solenoids and Lines - W/Out Sweetener .....	10
Strainer/Flow Control, Solenoids and lines - W/Sweetener .....	14
Tank Assembly .....	8
Top Cover, Hood, Trunk, Base and Panels .....	4

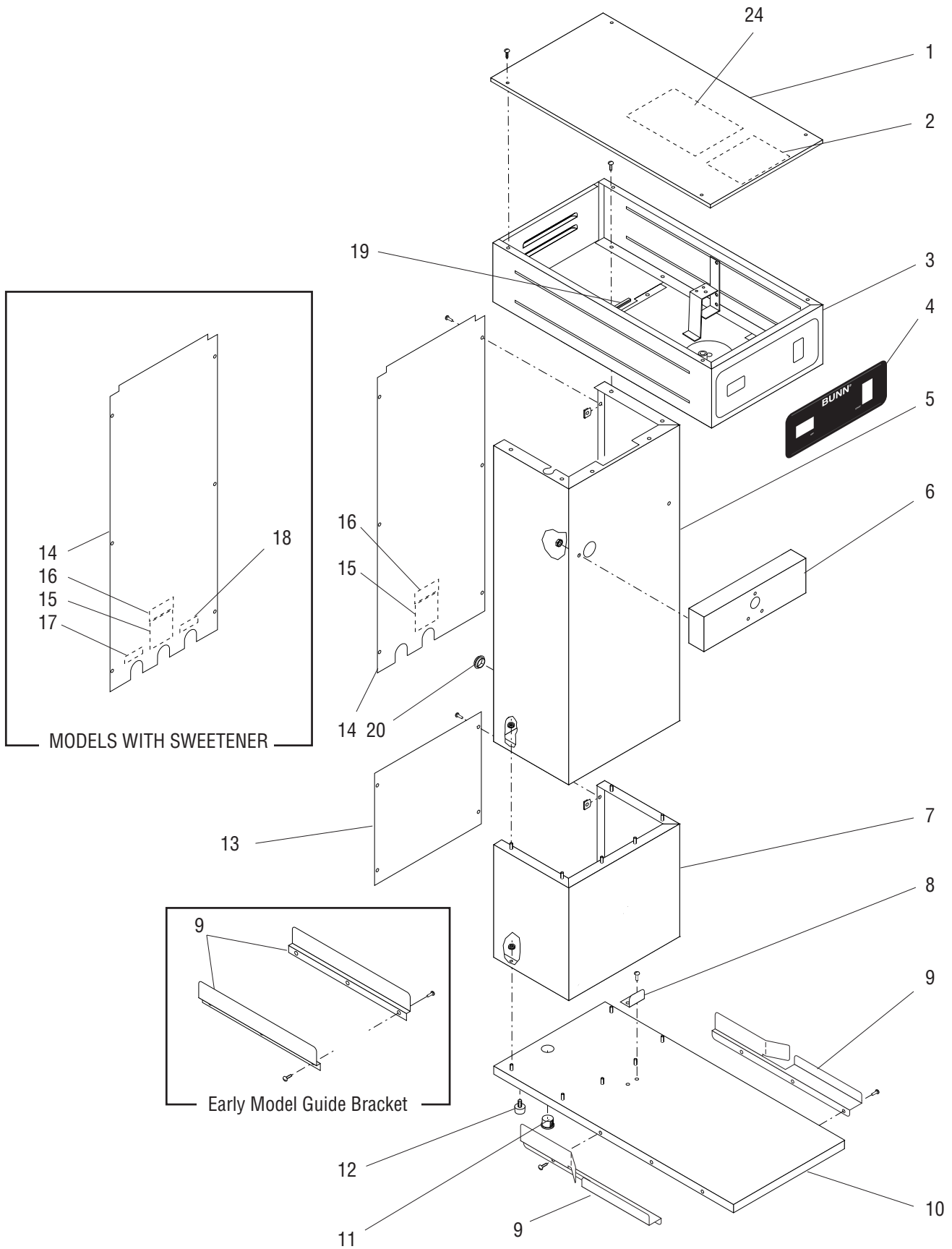

## TOP COVER, HOOD, TRUNK, BASE AND PANELS

ITEM	PART NO.	QTY.	DESCRIPTION
1	03423.0000	1	Cover, Top (Also order items 2 & 24)
	03423.1000	1	Cover, Top (Includes 10299.0000 - item 2) (also order item 24)
	0342 3.1002	1	Cover, Top (Includes 10558.0000 - item 2) (also order item 24)
	01382.0000	4	Screw, Truss Head #6-32 x .375"
2	10299.0000	1	Schematic, Electrical 120V
	10233.0000	1	Schematic, Electrical 120V (Brewers with half batch option)
	27432.0000	1	Schematic, Electrical 120V (Brewers with sweetener)
	10558.0000	1	Schematic, Electrical 100V ("B" Models only)
3	03381.0000	1	Hood (Also order item 4)
	03381.0005	1	Hood (Brewers with ready light) (Also order item 4)
	02308.0000	6	Screw, Pan Head - Serrated #8-32 x .375"
4	03363.0000	1	Decal, Hood-Switch
	03363.0001	1	Decal, Hood-Switch (Brewers with ready light)
	03352.0000	1	Decal, Hood-Switch (Brewers with ready light & half batch option)
	22251.0000	1	Decal, Hood-Switch (Brewers with sweetener)
5	03762.0001	1	Trunk Assy
	03762.0002	1	Trunk Assy ("A" Models only)
	00970.0000	6	Nut, Hex Keps #8-32
6	03773.0000	1	Housing, Nozzle Mounting
	00970.0000	2	Nut, Hex Keps #8-32
7	03765.0001	1	Housing Assy, Trunk Extension 6.12" HT
	03765.0002	1	Housing Assy, Trunk Extension 3.0" HT
	03765.0003	1	Housing Assy, Trunk Extension 8.12" HT
	00970.0000	6	Nut, Hex Keps #8-32 ( 6 additional required for 26" servers)
8	03770.0000	1	Bracket, Stop
	01315.0000	2	Screw, Truss Head #8-32 x .375"
9	03772.0000	2	Guide, Base (Early models)
	32035.0000	1	Guide, Base (Left side)
	32035.0001	1	Guide, Base (Right side)
	01317.0003	6	Screw, Pan Head - Locking #8-32 x .375"
10	03767.0000	1	Base
11	00668.0000	1	Plug, Hole .75" Dia
12	25137.0001	4	Foot, .75" O.D. x .44" HT (See item 21)
13	03771.0001	1	Cover, Trunk Extension - Rear 6.12" HT
	03771.0002	1	Cover, Trunk Extension - Rear 3.0" HT
	03771.0003	1	Cover, Trunk Extension - Rear 8.12" HT
	01315.0000	4	Screw, Truss Head #8-32 x .375"
	00917.0000	4	Fastener, J-Type #8-32
14	25615.0000	1	Panel W/Decals, Trunk (Includes items 15 & 16)
	22297.0000	1	Panel W/Decals, Trunk (Includes items 15 thru 18) (Brewers with sweetener)
	01315.0000	6	Screw, Truss Head #8-32 x .375"
	00917.0000	6	Fastener, J-Type #8-32
15	00831.0000	1	Decal, Electrical Warning

For 26" Servers

See item 23

Late models

For 26" Servers

4 additional required for 26" servers

See item 23

(Continued)

(Continued)

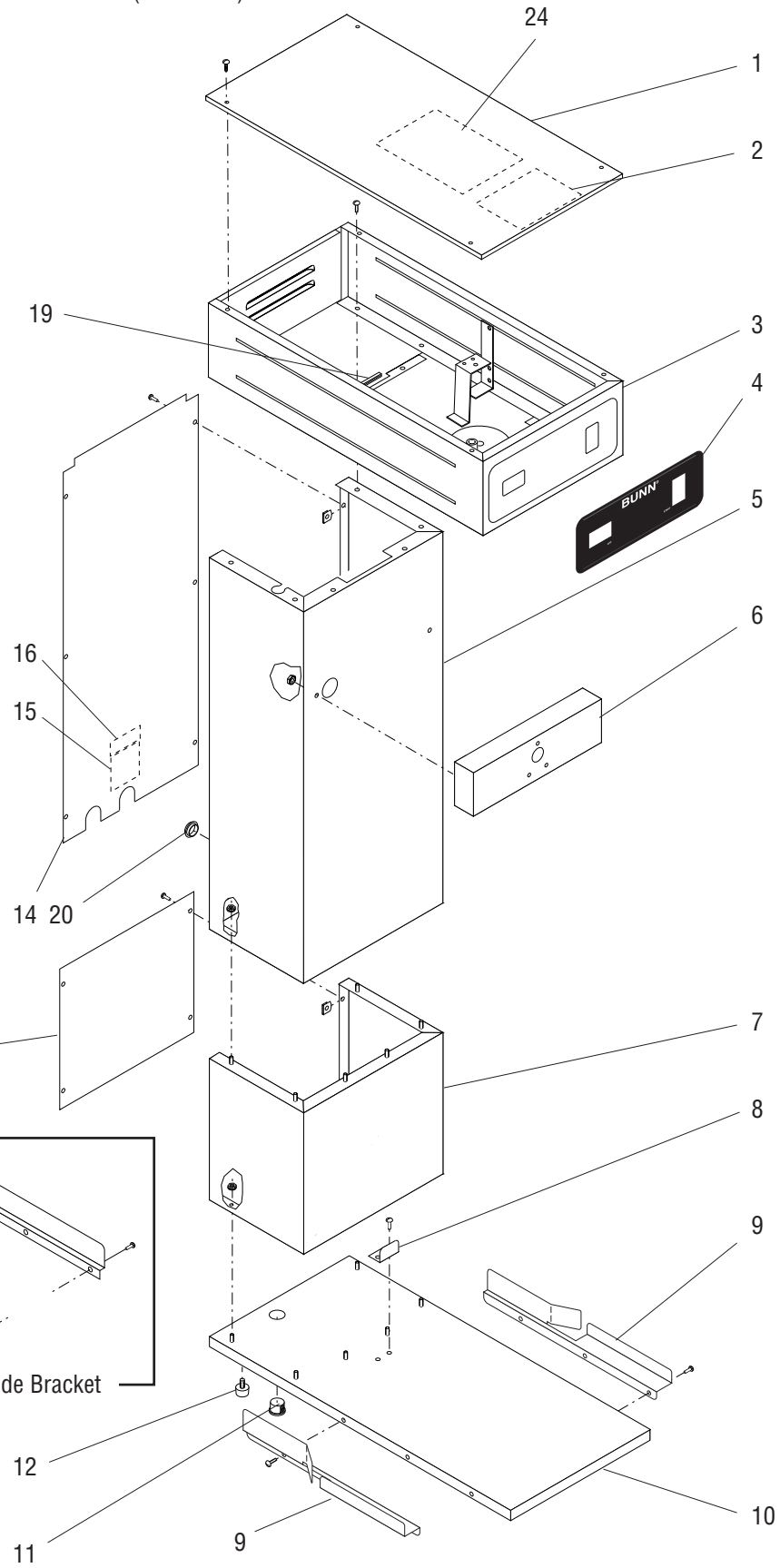
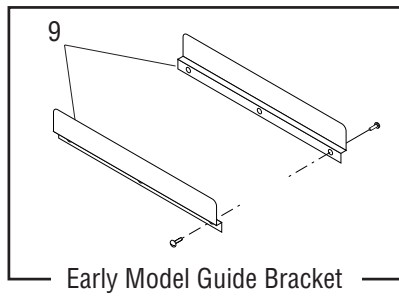
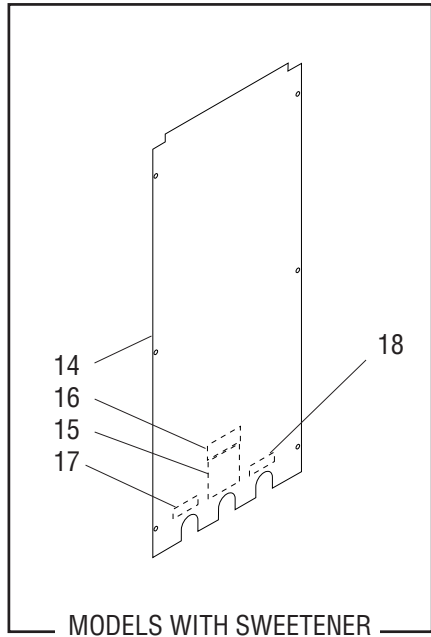

## TOP COVER, HOOD, TRUNK, BASE AND PANELS

ITEM	PART NO.	QTY.	DESCRIPTION
16	00656.0000	1	Decal, Comply With Plumbing Code
17	26371.0000	1	Decal, Water Inlet
18	26371.0001	1	Decal, Sweetener Inlet
19	-----	1	Edging, 2" LG (Order item 22)
20	05749.0001	1	Plug, Hole .625" Dia ("A" Models only)
21	24600.0000	-	Kit, Foot (Includes four feet)
22	02712.1000	-	Edging, 18" LG
23	03760.0001	-	Trunk Extension Kit, 6.12" HT (Includes items 7, 13 & Hardware)
	03760.0002	-	Trunk Extension Kit, 3.0" HT (Includes items 7, 13 & Hardware)
	03760.0003	-	Trunk Extension Kit, 8.12" HT (Includes items 7, 13 & Hardware)
24	32540.0000	1	Decal, Batch Set (Digital Timer) (Late Models)

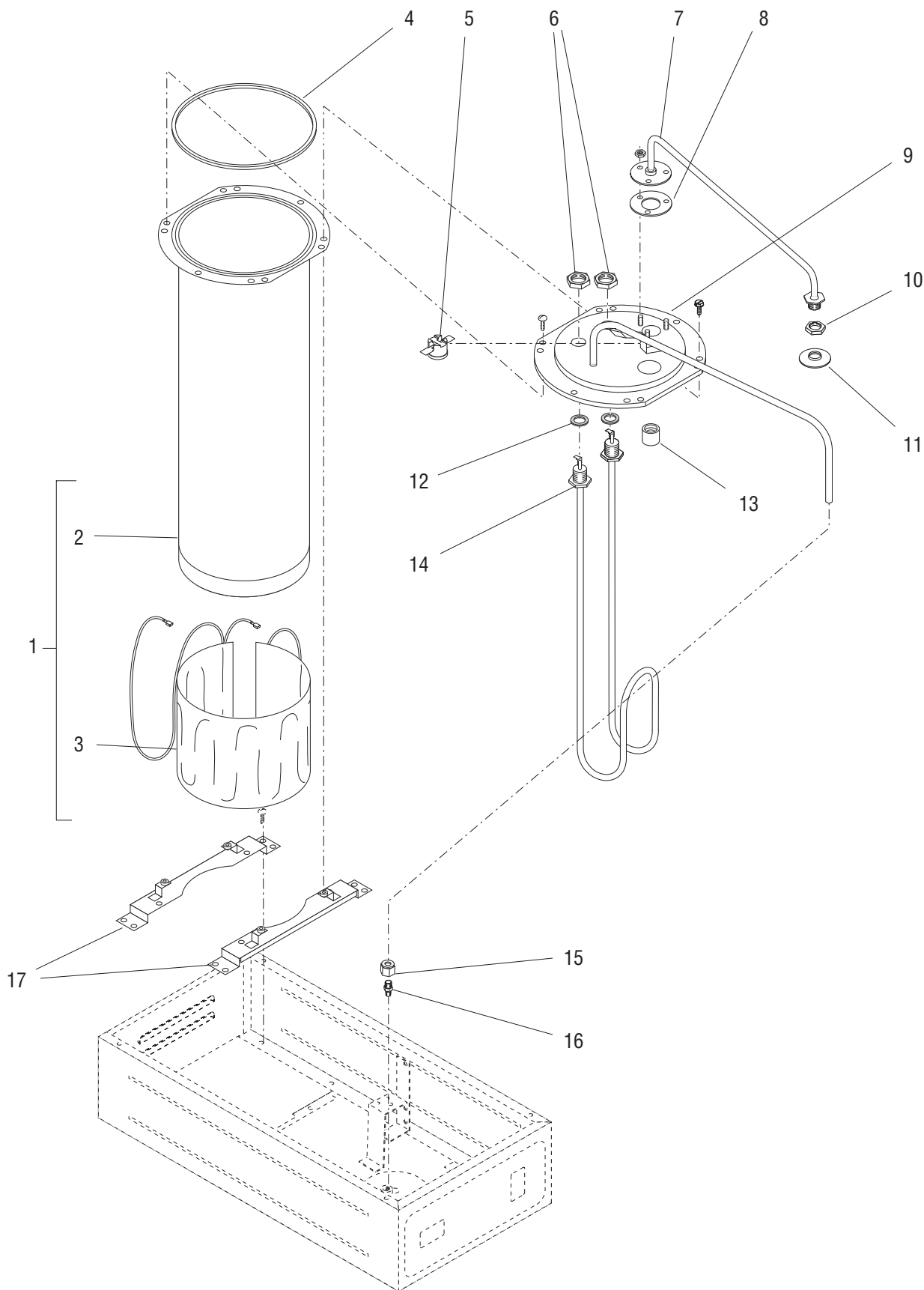



## TANK ASSEMBLY

ITEM	PART NO.	QTY.	DESCRIPTION
-	05696.0007	1	Tank Assembly, 1680W 120V (Includes items 1 thru 9, 12, 13, 14)
-	-----	1	Tank Assembly, 1680W 100V (Includes items 2, 4 thru 9, 12, 13, 14)( Not Available. Order components)
-	-----	1	Tank Assembly, 1680W 230V (Includes items 1 thru 9, 12, 13, 14) (Not Available. Order Components)
	01315.0000	4	Screw, Truss Head #8-32 x .375"
1	03045.0000	1	Tank W/Blanket Warmer 120V (Includes items 2 &3)
	03045.0003	1	Tank W/Blanket Warmer 230V (Includes items 2 &3)
2	03068.0000	1	Tank
3	03468.0000	1	Blanket Warmer, 55W 120V
	03470.0000	1	Blanket Warmer, 55W 230V
4	04844.0000	1	Gasket, Tank Lid
5	29329.1000	1	Thermostat, Limit 15 amp
6	00942.0000	2	Nut, Hex .50"-20
7	05557.0000	1	Sprayhead Tube Kit (Includes 3 mounting nuts below, items 8 & 13)
	00908.0000	3	Nut, Hex #8-32
8	05515.0000	1	Gasket, Sprayhead Tube
9	03371.0000	1	Lid Assembly, Tank
	02337.0002	6	Screw, Hex Head Thread Forming #10 x .50"
10	01075.0000	1	Nut, Hex .438"-20
11	01082.0000	1	Sprayhead, 6 Hole
	01082.0003	1	Sprayhead, 7 Hole
12	00943.0000	2	Gasket, Tank Heater
13	05518.0000	1	Syphon Hub
14	03070.1000	1	Tank Heater, 1680W 120V
	03299.1000	1	Tank Heater, 1680W 230V
	03297.1000	1	Tank Heater, 1680W 100V
			} Includes item 12
15	00929.0001	1	Nut/Sleeve, .375" Tube
16	00406.0001	1	Fitting, .375" Tube x .125" MPT
17	03387.0000	2	Bracket, Tank Mounting
	02308.0000	4	Screw, Pan Head #8-32 x .375"

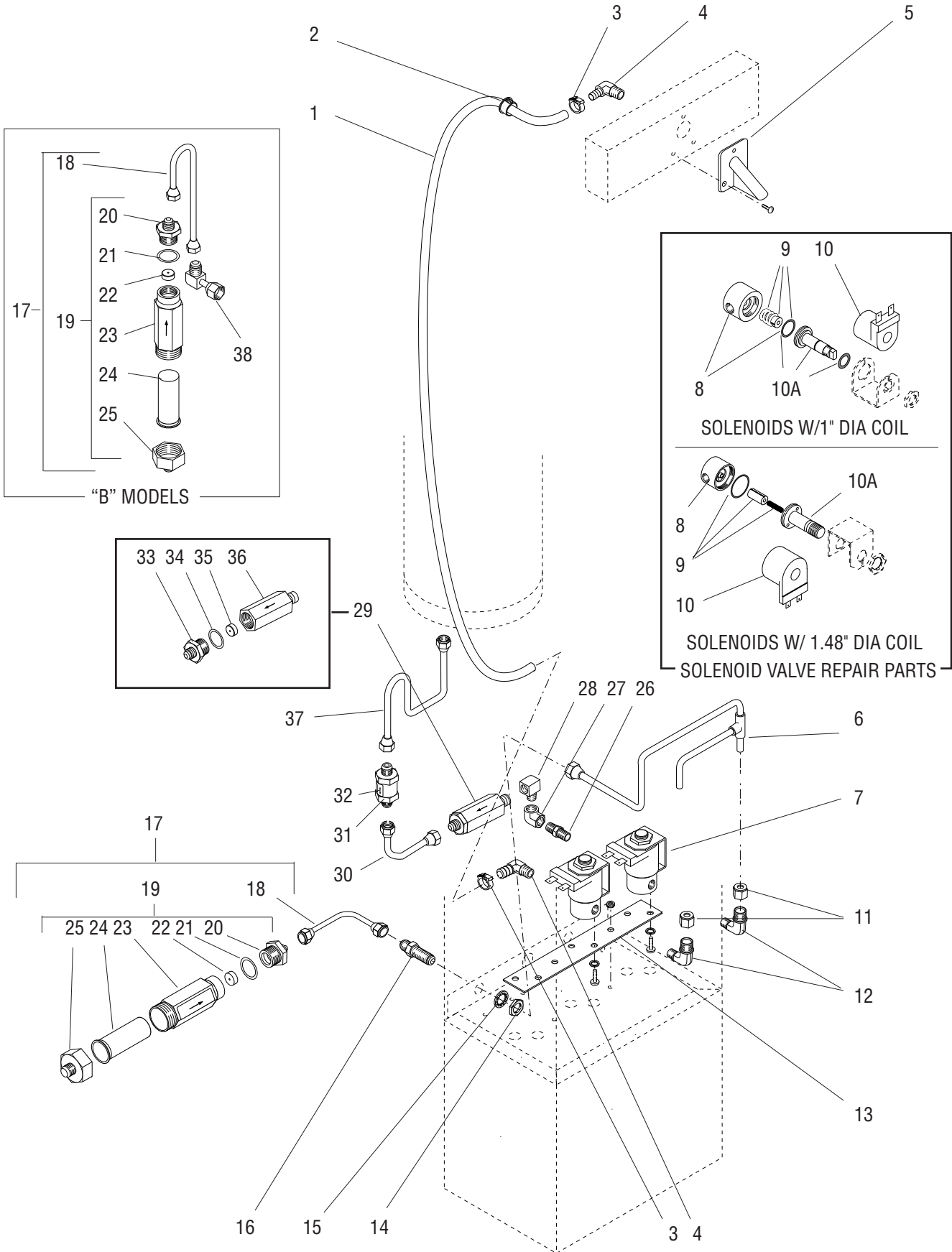

## STRAINER/FLOW CONTROL, SOLENOIDS AND LINES W/OUT SWEETENER

ITEM	PART NO.	QTY.	DESCRIPTION
1	-----	1	Tube, Silicone, .250" I.D. x 23" LG (Order item 39)
2	01592.0000	1	Bushing, Snap 1" Dia Hole
3	12422.0000	2	Clamp, Hose - Snap Type .47"/.54" I.D.
4	00464.0001	2	Elbow, .250" Barb x .125" MPT
5	03717.0000	1	Nozzle, Dilution
	01382.0000	3	Screw, Truss Head Serrated #6-32 x .375"
6	25523.0000	1	Tube Assembly, Solenoids to Bulkhead (Includes items 11)
7	-----	2	Solenoid Valve, 120V - 1.48" Dia Coil (Not Available. Order 01085.0002)
	01085.0002	2	Solenoid Valve, 120V - 1" Dia Coil
	01975.0000	2	Solenoid Valve, 240V - 1.48" Dia Coil
	01138.0000	2	Solenoid Valve, 100V - 1.48" Dia Coil
	01327.0000	4	Screw, Pan Head #10-32 x .375"
	01502.0000	4	Lockwasher, Split #10
8	01079.0000	1	Solenoid Valve Base - 1.48" Dia Coil
	28479.0000	1	Solenoid Valve Base Kit -1" Dia Coil (Includes O-ring)
9	01111.0000	1	Solenoid Valve Repair Kit - 1.48" Dia Coil (Includes Plunger, Seal and Spring)
	01111.0002	1	Solenoid Valve Repair Kit - 1" Dia Coil (Includes Plunger, Spring and O-ring)
10	01101.0000	1	Solenoid Valve Coil, 120V - 1.48" Dia Coil
	28480.0000	1	Solenoid Valve Coil, 120V - 1" Dia Coil
	01100.0000	1	Solenoid Valve Coil, 240V - 1.48" Dia Coil
	01139.0000	1	Solenoid Valve Coil, 100V - 1.48" Dia Coil
10A	01116.0000	1	Guide - 1.48" Dia Coil
	28481.0000	1	Guide Kit - 1" Dia Coil (Includes Washer and O-ring)
11	00443.0001	2	Nut/Sleeve, .250" Tube
12	00465.0001	2	Elbow Assembly, .125" MPT x .250" Tube (Includes item 11)
13	03170.0000	1	Plate, Solenoid Valve Mounting
	00970.0000	2	Nut, Keps #8-32
14	00463.0000	1	Nut, Hex - Brass .438"-20
15	01532.0000	1	Lockwasher, Internal Tooth .438"
16	00459.0000	1	Fitting, Bulkhead .250" Flare
17	24356.0750	1	Strainer/Flow Control W/Tubing (.750 GPM) (Includes items 18 & 19)
	28025.0750	1	Strainer/Flow Control W/Tubing (.750 GPM) (includes items 18 & 19) ("B" Models)
	28025.0330	1	Strainer/Flow Control W/Tubing (.330 GPM) (Includes Items 18 & 19) ("B" Models)
18	00310.0000	1	Tube Assembly, Strainer/Flow Control to Bulkhead
	28026.0000	1	Tube Assembly, Strainer/Flow Control to Elbow ("B" Models)
19	22300.0750	1	Strainer/Flow Control Assembly (Includes items 20 thru 25)
	22300.0330	1	Strainer/Flow Control Assembly (Includes items 20 thru 25)
20	01154.0000	1	Fitting, Flow Control Outlet

(Continued)

(Continued)

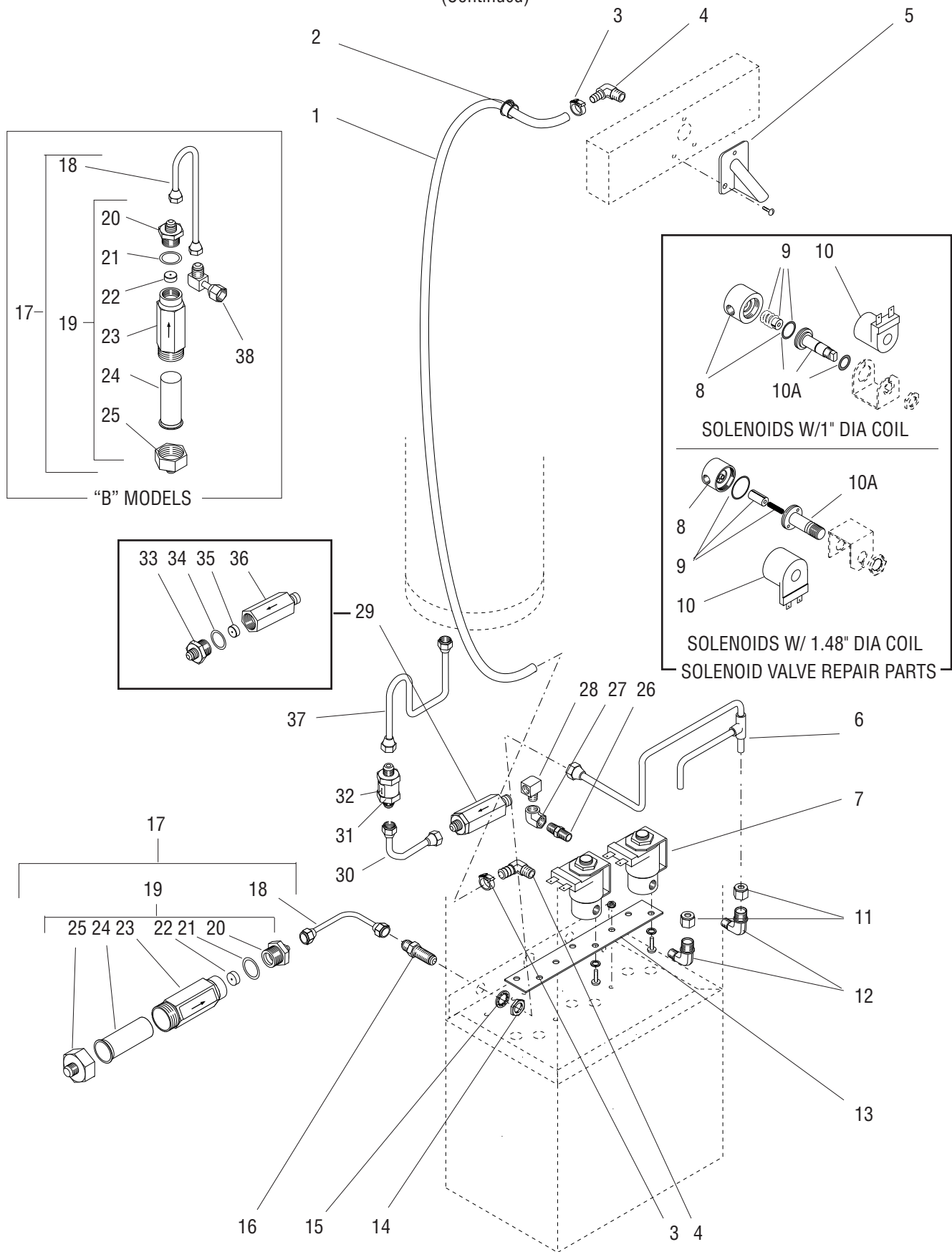

## STRAINER/FLOW CONTROL, SOLENOIDS AND LINES W/OUT SWEETENER

ITEM	PART NO.	QTY.	DESCRIPTION
21	01155.0000	1	Gasket, Flow Control
22	20526.1750	1	Flow Washer/Gasket Kit (.750 GPM) (Includes item 21)
	20526.1330	1	Flow Washer/Gasket Kit (.330 GPM) (Includes item 21) ("B" Models)
23	-----	1	Body (Not Available. Order item 19)
24	23721.0000	1	Screen
25	22249.0000	1	Fitting, Flow Control Inlet
26	00412.0001	1	Nipple, Hex .125" MPT
27	00435.0001	1	Elbow, .125" NPT Female
28	00432.0001	1	Elbow, .125" NPT Male/Female
29	20528.1195	1	Flow Control Assembly (.195 GPM) (Includes items 33 thru 36)
30	00310.0003	1	Tube Assembly, Flow Control to Check Valve
31	01171.0001	1	Valve, Check (Includes item 32) (Refer to item 40 for repair kit)
32	20554.0001	1	Decal, Check Valve
33	01154.0001	1	Fitting, Flow Control Outlet
34	01155.0000	1	Gasket, Flow Control
35	20526.1195	1	Flow Washer/Gasket Kit (.195 GPM) (Includes item 34)
36	-----	1	Body, Flow Control (Not Available. Order item 29)
37	03453.0000	1	Tube Assembly, Check Valve to Tank
38	00949.0000	1	Elbow ("B" Models)
39	11707.1001	-	Tube, Silicone .250" I.D. x .50" O.D. x 36" LG
	11707.1002	-	Tube, Silicone .250" I.D. x .50" O.D. x 120" LG
40	01170.0000	1	Check Valve Repair Kit (Contains a gasket, spring & seat assembly) (Not Illustrated)























